



ABC Phonics Word Builder™



Parent's Guide

This guide contains important information. Please keep it for future reference.

INTRODUCTION

Thank you for purchasing the **ABC Phonics Word Builder™!**

Learn letters and their sounds and blend those sounds into words with this fun and interactive device. Play six learning games to explore 250+ words, letter sounds and spelling. Use the three activity cards to practice vowel letters and consonant letters.



INCLUDED IN THIS PACKAGE

- ABC Phonics Word Builder™
- 3 Double-sided Activity Cards
- Parent's guide

WARNING

All packing materials such as tape, plastic sheets, packaging locks, removable tags, cable ties and packaging screws are not part of this toy and should be discarded for your child's safety.

NOTE

Please keep this parent's guide as it contains important information.

ATTENTION

Pour la sécurité de votre enfant, débarrassez-vous de tous les produits d'emballage tels que rubans adhésifs, feuilles de plastique, attaches, étiquettes et vis d'emballage. Ils ne font pas partie du jouet.

NOTE

Il est conseillé de conserver ce guide des parents car il comporte des informations importantes.

Unlock the Packaging Locks

- ① Rotate the packaging locks 90 degrees counterclockwise.
- ② Pull out the packaging locks and discard.

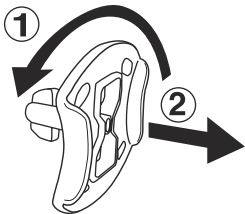

GETTING STARTED

BATTERY REMOVAL AND INSTALLATION

1. Make sure the unit is turned **Off**.
2. Locate the battery cover located on the back of the unit and use a screwdriver or coin to loosen the screw and open the battery cover.
3. Remove old batteries by pulling up on one end of each battery.
4. Install 2 new AA (AM-3/LR6) batteries following the diagram inside the battery box.
5. Replace the battery cover and tighten the screw to secure.

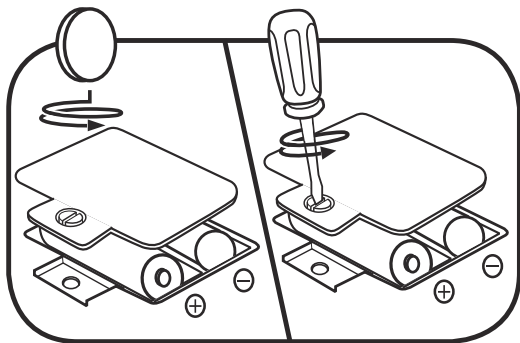

BATTERY NOTICE

- Use new alkaline batteries for maximum performance.
- Use only batteries of the same or equivalent type as recommended.
- Do not mix different types of batteries: alkaline, standard (carbon-zinc) or rechargeable, or new and used batteries.
- Do not use damaged batteries.
- Insert batteries with the correct polarity (+ and -).
- Do not short-circuit the battery terminals.
- Remove exhausted batteries from the toy.
- Remove batteries during long periods of non-use.
- Do not dispose of batteries in fire.
- Do not charge non-rechargeable batteries.
- Remove rechargeable batteries from the toy before charging (if removable).
- Rechargeable batteries are only to be charged under adult supervision.

MISE EN GARDE

- Utiliser des piles alcalines neuves pour des performances maximales.
- Seules des piles du type recommandé doivent être utilisées.
- Ne pas mélanger différents types de piles ou d'accumulateurs, ne pas mélanger des piles ou des accumulateurs neufs avec des usagés.
- Ne pas utiliser des piles ou des accumulateurs endommagés.
- Mettre en place les piles ou les accumulateurs en respectant les polarités + et -.
- Ne pas mettre les bornes d'une pile ou d'un accumulateur en court-circuit (en reliant directement le + et le -).
- Enlever les piles ou les accumulateurs usagés du jouet.
- Retirer les piles ou les accumulateurs en cas de non-utilisation prolongée.
- Ne les jeter ni au feu ni dans la nature.
- Ne pas tenter de recharger des piles non rechargeables.
- Enlever les accumulateurs du jouet pour les recharger.
- Les accumulateurs ne doivent être chargés que sous la surveillance d'un adulte.

PRODUCT FEATURES

1. Power Button

Press the **Power Button** to turn the toy on and put the toy to sleep.

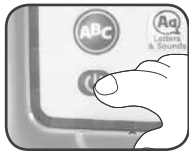

2. Sound Slider

Move the **Sound Slider** left or right to interact with the objects on the screen.



3. Star Button

Press the **Star Button** to select letters and interact with the objects on the screen.

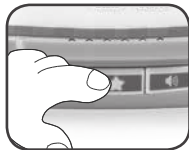

4. Contrast Button

Press the **Contrast Button** to access the contrast adjustment screen. Then,

- Move the **Sound Slider** left or right to adjust the contrast setting.
- Press the **Star Button** to confirm the contrast setting and exit the screen.



5. Volume Button

Press the **Volume Button** to access the volume adjustment screen. Then,

- Move the **Sound Slider** left or right to adjust the volume setting.
- Press the **Star Button** to confirm the volume setting and exit the screen.



6. Letter Select Button

Press the Letter **Select Button** to access the letter select screen. Then,

- Move the **Sound Slider** left or right to scroll through the alphabet.
- Press the **Star Button** to select a letter and play different activities associated with that letter.

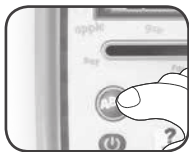

7. Activity Mode Buttons

Press any of the **Activity Mode Buttons** to play one of six different learning activities.

- Letters & Sounds
- Flash Cards
- Sound Blender
- Word Guess
- Letter Bounce
- Spot the Difference



8. Handle

The **Handle** can be used to carry the device and to store the three **Activity Cards**.

- To store the **Activity Cards**, detach the **Handle** from the back of the device.
- Slide the **Handle** through the loops on the **Activity Cards**.
- Reattach the **Handle** to the back of the device.



9. Activity Cards

The three double-sided **Activity Cards** can be inserted into the device to instantly access specific learning activities.

- Aa - Vowel letter A curriculum
- Ee - Vowel letter E curriculum
- Ii - Vowel letter I curriculum
- Oo - Vowel letter O curriculum
- Uu - Vowel letter U curriculum
- XYZ - Consonant letters curriculum

Remove the **Activity Card** from the device to access the **Power Button**, the **Letter Select Button**, and the six **Activity Mode Buttons**.



10. Automatic Shut-Off

To preserve battery life, **ABC Phonics Word Builder™** will automatically shut off after approximately 45 seconds to one minute without input. To turn the unit on again, press the **Power Button**, insert an **Activity Card** into the device, or remove an **Activity Card** from the device.

NOTE

If the unit powers down or the low battery image appears, please install a new set of batteries.

CARE & MAINTENANCE

1. Keep the unit clean by wiping it with a slightly damp cloth.
2. Keep the unit out of direct sunlight and away from direct heat sources.
3. Remove the batteries if the unit will not be in use for an extended period of time.
4. Do not drop the unit on hard surfaces and do not expose the unit to moisture or water.

TROUBLESHOOTING

If for some reason the unit stops working or malfunctions, please follow these steps:

1. Press the Power Button to put the toy to sleep.
2. Interrupt the power supply by removing the batteries.
3. Let the unit stand for a few minutes, then replace the batteries.
4. Turn the unit back **On**. The unit should now be ready to use again.
5. If the unit still does not work, install a new set of batteries.

IMPORTANT NOTE

If the problem persists, please call our **Consumer Services Department** at **1-800-701-5327** in the U.S. or email **support@leapfrog.com**. Creating and developing **LeapFrog®** products is accompanied by a responsibility that we take very seriously. We make every effort to ensure the accuracy of the information, which forms the value of our products. However, errors sometimes can occur. It is important for you to know that we stand behind our products and encourage you to contact us with any problems and/or suggestions you might have. A service representative will be happy to help you.

Environmental phenomena

The unit may malfunction if subjected to radio-frequency interference. It should revert to normal operation when the interference stops. If not, it may become necessary to turn the power **OFF** and back **ON**, or remove and reinstall the batteries. In the unlikely event of an electrostatic discharge, the unit may malfunction and lose memory, requiring the user to reset the device by removing and reinstalling the batteries.

Impact de l'environnement

Une défaillance de fonctionnement de l'appareil peut survenir s'il est sujet à des interférences avec les fréquences radioélectriques. Le fonctionnement normal de l'appareil devrait reprendre avec l'arrêt des interférences. Si ce n'est pas le cas, il peut s'avérer nécessaire d'éteindre et rallumer l'appareil ou de retirer et réinstaller les piles. Dans l'éventualité peu probable d'une décharge électrostatique, un mauvais fonctionnement et une perte de mémoire de l'appareil peuvent se produire. L'utilisateur doit alors retirer et réinstaller les piles pour réinitialiser l'appareil.

CAUTION

Changes or modifications not expressly approved by the party responsible for compliance could void the user's authority to operate the equipment.

NOTE

This equipment has been tested and found to comply with the limits for a Class B digital device, pursuant to Part 15 of the FCC Rules. These limits are designed to provide reasonable protection against harmful interference in a residential installation. This equipment generates, uses and can radiate radio frequency energy and, if not installed and used in accordance with the instructions, may cause harmful interference to radio communications. However, there is no guarantee that interference will not occur in a particular installation. If this equipment does cause harmful interference to radio or television reception, which can be determined by turning the equipment off and on, the user is encouraged to try to correct the interference by one or more of the following measures:

- Reorient or relocate the receiving antenna
- Increase the separation between the equipment and receiver
- Connect the equipment into an outlet on a circuit different from that to which the receiver is connected
- Consult the dealer or an experienced radio/TV technician for help

Supplier's Declaration of Conformity
47 CFR § 2.1077 Compliance Information

Trade Name: LeapFrog®
Model: 6111
Product Name: **ABC Phonics Word Builder™**
Responsible Party: LeapFrog Enterprises, Inc.
Address: 6401 Hollis Street, Suite 100
Emeryville, CA 94608
Website: leapfrog.com

THIS DEVICE COMPLIES WITH PART 15 OF THE FCC RULES.
OPERATION IS SUBJECT TO THE FOLLOWING TWO CONDITIONS:
(1) THIS DEVICE MAY NOT CAUSE HARMFUL INTERFERENCE,
AND (2) THIS DEVICE MUST ACCEPT ANY INTERFERENCE
RECEIVED, INCLUDING INTERFERENCE THAT MAY CAUSE
UNDESIRE OPERATION.

CAN ICES-3 (B)/NMB-3(B)

CLASS 1
LED PRODUCT



*Visit our website for more
information about our products,
downloads, resources and more.*

leapfrog.com

***Read our complete warranty policy online at
leapfrog.com/warranty.***

LeapFrog Enterprises, Inc.
A subsidiary of VTech Holdings Limited.
TM & © 2020 LeapFrog Enterprises, Inc.
All rights reserved.
Printed in China.
91-003842-000 